

ROTTTEFELLA

QUICKLOCK & QUICKLOCK TOURING FOR IFP*



For roller ski: Use Rotttefella Rollerski binding.

- 1 Find your shoe size:** Turn the heel plate and the binding house with the underside up. Fit the heel plate in the binding house by pressing the forks on the heel plate under the tabs on both sides of the binding house. Fix them in the right position for your shoe size. Turn the binding upright.

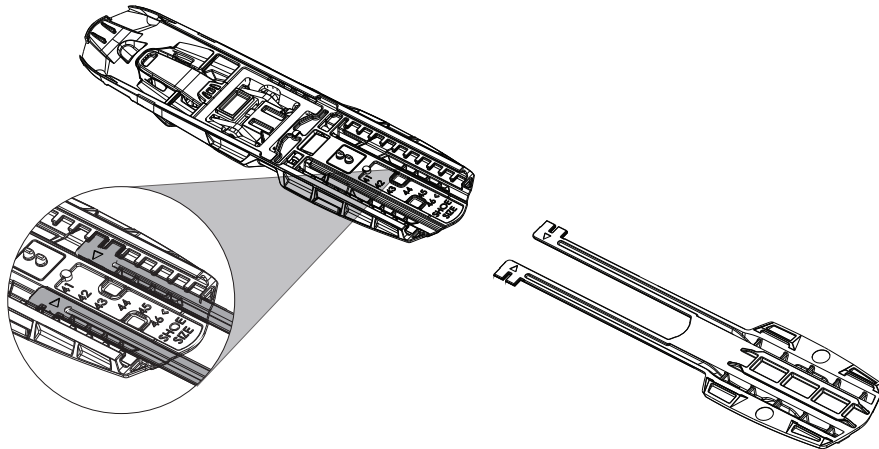

- 2 Mounting the binding:** Lift the Quicklock. Slide the rear of the binding house onto the front of the mounting plate. The tracks on the underside of the binding house should grasp the tracks on the sides of the mounting plate. The heel needs to grasp the heel of the mounting plates. Slide the binding until "0", neutral position, appears in the window. Close the Quicklock and you are ready!

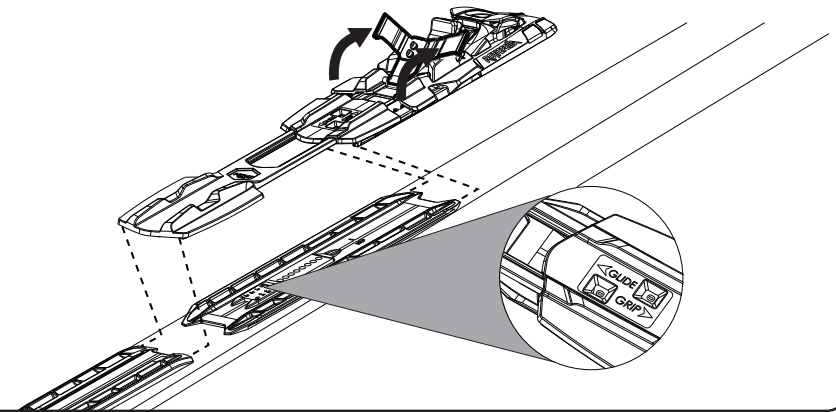

- 3 For better grip:** Lift the Quicklock and push the binding forwards to preferred position, choose between three different positions, +1, +2, +3 for better grip. Close the Quicklock. The position is indicated in the window.

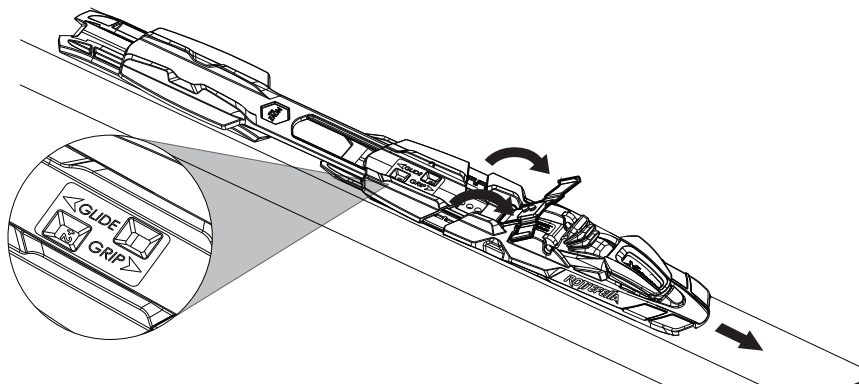

- 4 For better glide:** Lift the Quicklock and push the binding backwards to preferred position, choose between three different positions, -1, -2, -3 for better glide. Close the Quicklock. The position is indicated in the window.

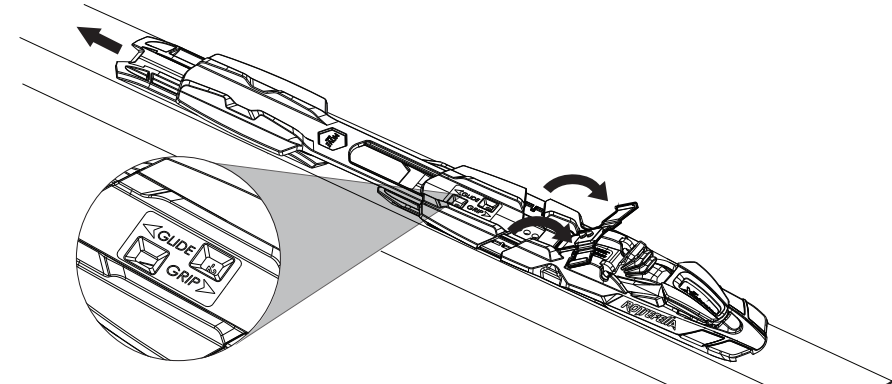

Join us outdoors