

ROTTEFELLA XPLORE

ROTTEFELLA XPLORE™ OFF-TRACK

The new binding system provides increased mobility when skiing across all types of terrain and enhanced stability during downhill skiing.



HOW TO ENTER AND EXIT ROTTEFELLA XPLORE OFF-TRACK BINDING

ENTERING THE BINDING

Align the shoe SpringPin™ connection point with the tracks in the binding and step down until you hear a click.

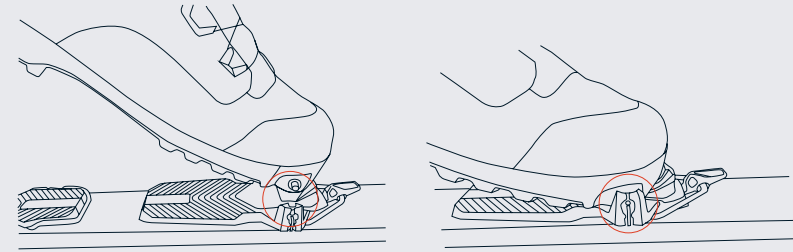

EXITING THE BINDING

Use your ski pole or a thumb to push down the button at the front of the binding.

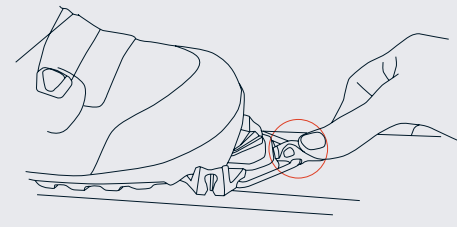

HOW TO MOUNT ROTTEFELLA XPLORE™ BINDING

PREPARE THE SKIS

1 Mounting the Rottefella jig

Find the balance point of the skis and draw a line.

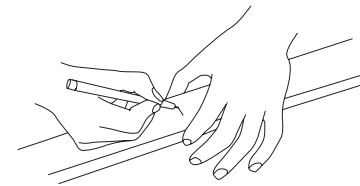

Place the Xplore inserts into the Rottefella jig and adjust to the correct shoe size.

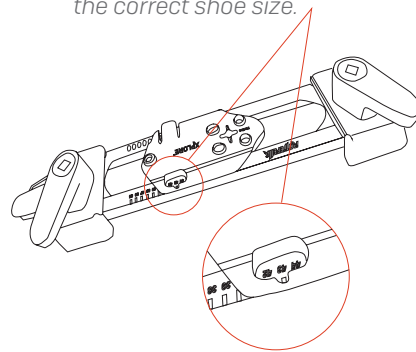

Find the marked line on the skis through the PIN LINE window. Lock the Rottefella jig to the skis using the clamps.

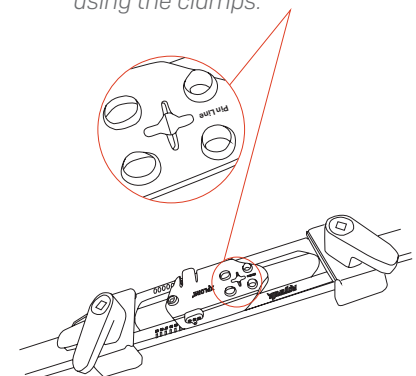

2 Drilling and preparing the skis

The insert has alignment holes so you always drill the screw holes correctly. Use the recommended drill bit size for correct depth and diameter.

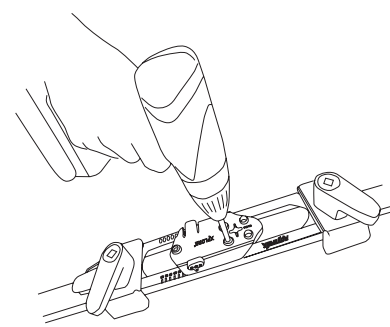

Drill bit (screw length = 16.3 mm): 3.6x9 mm

Drill bit (screw length = 21.8 mm): 3.6x15.5 mm

Pour glue in the holes to avoid moisture penetrating into the skis. Follow the recommendations from the ski producers on type of glue.

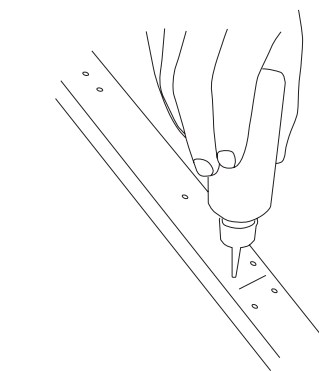

MOUNT THE BINDING

1 Mounting of binding house and heel

Align the binding house holes with the predrilled ones in the ski. Use the screws included with the binding and screw the binding into place. Tighten by hand.

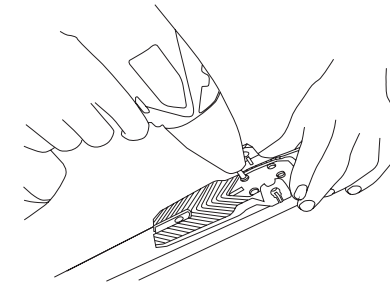

Place the heel lifter as shown and then place the heel plate on top, again aligning it with the pre drilled holes in the ski.

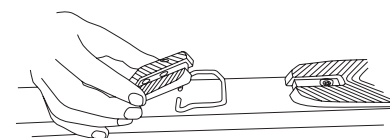

Use resistance 3 on the drill to ensure no damage will be done to the skis while screwing in the screws. Tighten by hand.

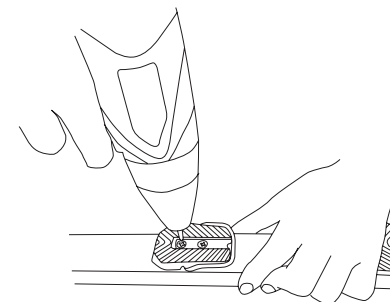

1 Mounting of flex

Place the tip of the included allround flex into the front of the binding first.

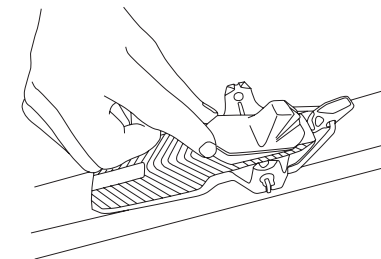

Push the rear part of the flex down until it locks into place.

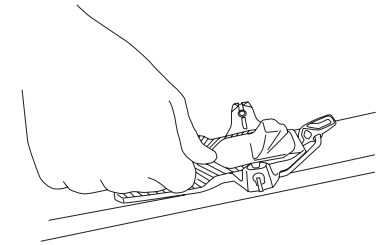

To release the flex push the release button on the left side.

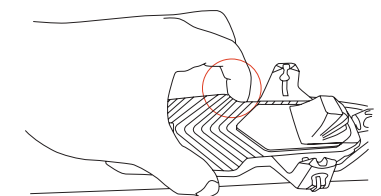

You can change to a Rottefella hard flex for more control during downhill skiing or to the Rottefella free pivot plate for a maximum range of rotation in steeper terrain.

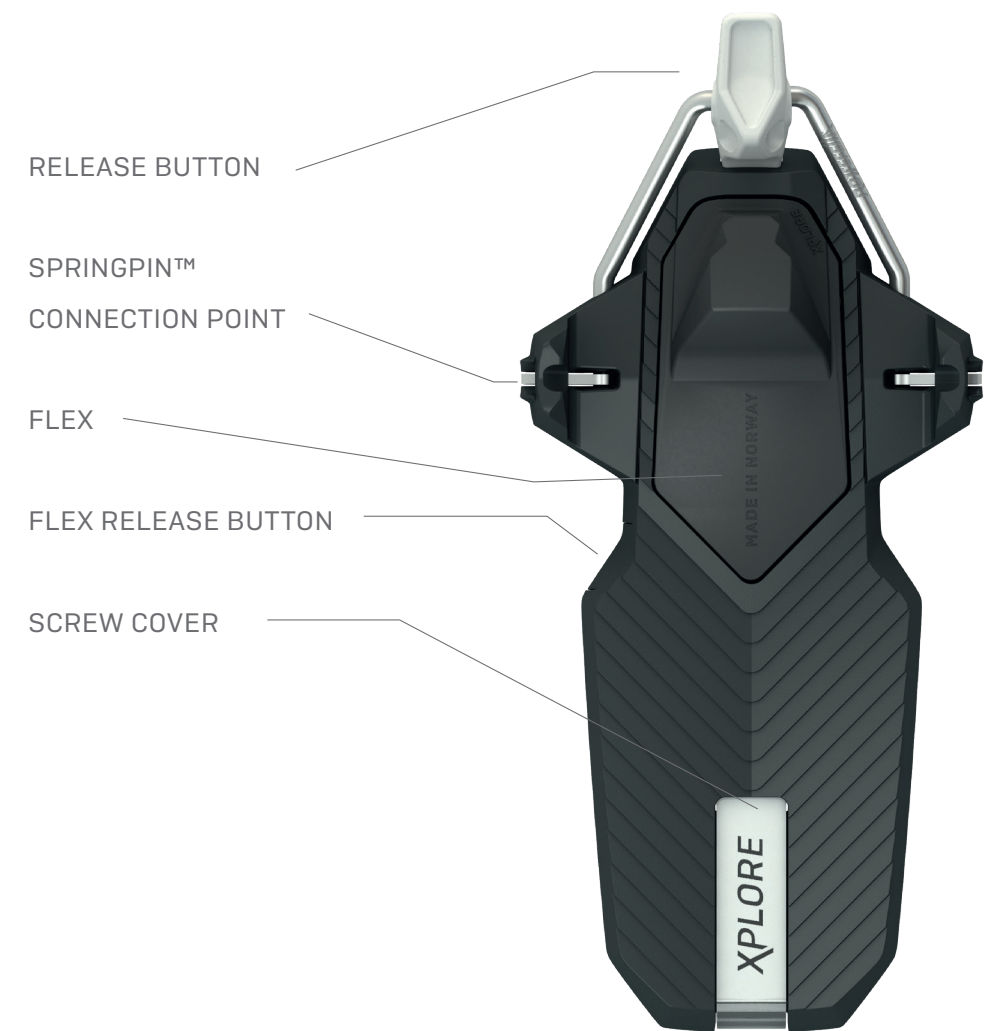

BINDING HOUSE

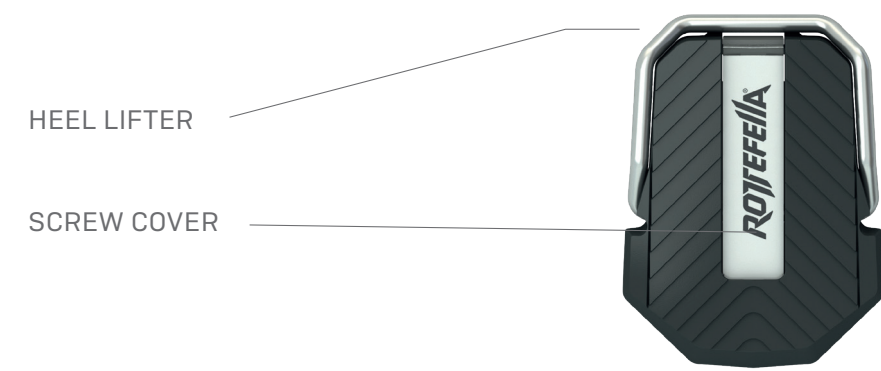

HEEL PLATE

ROTTEFELLA XPLORE ACCESSORIES



ROTTEFELLA HARD FLEX

Change the flex that comes with the system to a harder flex for more control when skiing downhill.



ROTTEFELLA FREE-PIVOT-PLATE

Change the flex that comes with the system to a free-pivot-plate for maximum range of rotation in steeper terrain or for more comfortable walking when pulling a pulk.



ROTTEFELLA LEASH

The leash is an easy to use, durable and functional ski stopper.

NB! The Rottefella Xplore binding is not an automatic release binding.

Warning: Skiing is dangerous. If you use our equipment, it is your responsibility to learn the proper use of this equipment, and you accept all risks inherent in skiing, including those of injury to any part of the body, paralysis and death. This equipment is designed for skiing only, has limitations and must not be used for any other purposes. **NOTE: This binding does not have an automatic release mechanism.** The skier is therefore using this binding at his/her own risk.